

Phylogeny and biogeography of *Lentinula* inferred from an expanded rDNA dataset

DAVID S. HIBBETT, KAREN HANSEN AND MICHAEL J. DONOGHUE

Harvard University Herbaria, Cambridge, Massachusetts, 02138 U.S.A.

Phylogeny and biogeography of *Lentinula*, which includes cultivated shiitake mushrooms, were investigated using parsimony analyses of an expanded nuclear ribosomal DNA dataset. *Lentinula* occurs in the New World as well as Asia and Australasia. The Asian–Australasian *Lentinula* populations appear to form a clade, but species limits within this group are controversial. We refer to the entire Asian–Australasian *Lentinula* clade as shiitake. Thirty-seven wild-collected isolates of shiitake were examined, representing Australia, Borneo, China, Japan, Korea, Nepal, New Zealand, Papua New Guinea (PNG), Tasmania and Thailand. Five isolates of the New World species, *L. boryana*, were included for rooting purposes. Levels of sequence divergence between North and Central American *L. boryana* isolates are higher than those between the most divergent shiitake isolates. In shiitake, five independent lineages of rDNA were identified, which we call groups I–V, but relationships among these lineages are not well resolved. Group I includes populations from northeast Asia to the South Pacific. Group II includes populations from PNG, Australia and Tasmania. Group III is limited to New Zealand. Group IV is from PNG. Finally, group V is from eastern China and Nepal. The distribution of rDNA lineages suggests a complex biogeographic history. Although many areas remain unsampled, our results suggest that certain areas have particularly high levels of diversity and should be targeted for further study and conservation.

Lentinula is a group of wood-decaying basidiomycetes that is best known as the genus of cultivated shiitake mushrooms. Wild populations of *Lentinula* occur in Asia, Australasia and the Americas. Two species of *Lentinula* are reported from the New World: *L. boryana*, which occurs in northern South America, Central America and the Gulf Coast of North America, and *L. guarapiensis*, which is known only from a single collection from Paraguay (Pegler, 1983). Species limits in the Asian–Australasian *Lentinula* population, which we collectively refer to as shiitake, are controversial (for reviews of *Lentinula* taxonomy, see Pegler, 1983; Hibbett, 1992; Hibbett *et al.*, 1995 and references therein). Pegler (1983) suggested that shiitake comprises three morphological species: *L. edodes* (continental and northeast Asia), *L. lateritia* (tropical Asia and Australasia), and *L. novaezelandiae* (New Zealand). Mating compatibility studies have demonstrated that all three morphological species are interfertile, and on this basis some authors have suggested that all of shiitake should be classified as a single species (e.g. Shimomura *et al.*, 1992).

This paper reports progress in our ongoing research on the phylogeny of *Lentinula*. In a previous study (Hibbett *et al.*, 1995), we found that there are four distinct lineages of *Lentinula* in Asia–Australasia, based on phylogenetic analyses of nuclear ribosomal DNA (rDNA) sequences. We called the rDNA lineages groups I–IV and suggested that these could be recognized as phylogenetic species (assuming that the rDNA phylogeny is congruent with the population phylogeny). In general, there was a high degree of congruence between the rDNA groups and geographic ranges of the isolates. Group I isolates came from Japan, Thailand and Borneo. Group II was

found in Papua New Guinea (PNG) and Tasmania. Group III was limited to New Zealand. Finally, group IV was limited to PNG (as is group II). Although our study used a diverse set of isolates, there were many areas with indigenous *Lentinula* populations that were not represented, including China and Australia. The work presented here fills some of the gaps in our geographic sampling, and improves our understanding of the spatial distribution of genetic variation in shiitake.

MATERIALS AND METHODS

All sequences published by Hibbett *et al.* (1995) were included in the present study (GenBank accessions U33070–U33093). Fifteen new shiitake sequences were added, from isolates representing China (seven isolates), North Korea (two isolates), Australia (three isolates), Thailand, Nepal and PNG. Four additional isolates of *L. boryana*, from Mexico (two isolates), Costa Rica, and the Gulf Coast of North America, were also added (Table 1). All isolates were derived from natural populations.

Laboratory techniques generally followed procedures outlined in Hibbett *et al.* (1995). Most DNAs were isolated from freeze-dried, liquid-cultured mycelium (DNA of *L. boryana* DUKE HN2002 was isolated from dried fruiting bodies), using an SDS–NaCl extraction buffer, phenol–chloroform extraction, and GeneClean (Bio 101, La Jolla, California) purification or ethanol–sodium acetate precipitation. The internal transcribed spacers 1 and 2 (ITS1 and ITS2) and the 5.8S rDNA were symmetrically amplified using primers ITS4 and ITS5 (White *et al.*, 1990). These primers, and three

Table 1. Isolates examined (asterisks indicate new isolates)

	Culture number*	Locality
<i>Lentinula boryana</i> (Berk.) Pegler		
CRA*	RGT960624/09	Costa Rica, Guanacaste Conservation Area, Guanacaste Prov.
MEX1	IE 67/R39	Mexico, Veracruz, Xalapa
MEX2	IE 162/R52	Mexico, Veracruz, between Xalapa and La Joya
MEX3*	IE 17/R38	Mexico, Veracruz, between Xalapa and Coatepec
MEX4*	IE 154/R50	Mexico, Tamaulipas, Victoria City
USA*	DUKE HN2002	U.S.A., Louisiana
shiitake (= <i>L. edodes</i> (Berk.) Pegler, <i>L. lateritia</i> (Berk.) Pegler, <i>L. novaezealandiae</i> (Stev.) Pegler)		
AUS1*	RV95-376	Australia, Queensland, Bunya Mts Nat. Park
AUS2*	RV95-377	Australia, Queensland, Bunya Mts Nat. Park
AUS3*	RV95-378	Australia, Queensland, Bunya Mts Nat. Park
BOR	TMI-689	Borneo
CHN1*	STCL 124	China, Zhejiang Prov., Long Quan
CHN2*	STLC 125	China, Anhui Prov., Huang Shan
CHN3*	STCL 140	China, Sichuan Prov., Chongqing, Daipai Shan
CHN4*	STCL 149	China, Hubei Prov., Wuhan
CHN5*	HNL 1	China, Fujian Prov., Sha County
CHN6*	HNL 2	China, Sichuan Prov., Nanjiang County
CHN7*	HNL95416	China (Jiangsu Prov.?), Yangshan
JPN1	TMI-571	Japan, Shikoku, Ehime
JPN2	TMI-646	Japan, Kyushu, Miyazaki
JPN3	TMI-818	Japan, Okinawa
JPN4	TMI-941	Japan, Hokkaido
JPN5	TMI-951	Japan, Hokkaido
JPN6	TMI-1148	Japan, Okinawa
KOR1*	VB361	North Korea
KOR2*	VB355	North Korea
NEP*	TMI-1564	Nepal
NZL1	TMI-1172	New Zealand
NZL2	TMI-1449	New Zealand
NZL3	NZFS 156/PSUMCC 804	New Zealand
NZL4	NZFS 210/PSUMCC 803	New Zealand
NZL5	RHP7563	New Zealand
PNG1	TMI-1476	PNG, Central Prov., Albert-Edward Mt.
PNG2	TMI-1485	PNG, Central Prov., Albert-Edward Mt.
PNG3	TMI-1499	PNG, Simbu Prov., Mt. Wilhelm
PNG4	TMI-1502	PNG, Simbu Prov., Mt. Wilhelm
PNG5	DSH 92-143/PSUMCC 798	PNG, Morobe Prov., Wau, near Wau Ecology Inst.
PNG6	DSH 92-145/PSUMCC 799	PNG, Morobe Prov., Biaru Divide, WEI camp
PNG7	DSH 92-147/PSUMCC 800	PNG, Morobe Prov., Biaru Divide, WEI camp
PNG9*	DSH 92-148/PSUMCC 801	PNG, Morobe Prov., Biaru Divide, WEI camp
PBG8	DSH 92-149/PSUMCC 802	PNG, Morobe Prov., Biaru Divide, WEI camp
TAS	RHP3577	Tasmania
THL1	TMI-1633	Thailand
THL2*	PA. s.n.	Thailand

* Origins and donors of isolates, indicated by culture number prefixes, are as follows: HNL, Huang N. Lai, Sanming Mycological Institute, Fujian Prov., China. IE, Gerardo Mata, Instituto de Ecología AC, Xalapa, Veracruz, Mexico. NZFS, Geoff Ridley, New Zealand Forest Research Institute, Rotorua, New Zealand. PA, Pingam Arampongphan, Division of Plant Pathology and Microbiology, Department of Agriculture, Bangkok, Thailand. R and PSUMCC, Daniel J. Royle, Pennsylvania State University Mushroom Culture Collection, University Park, PA U.S.A. RGT, Greg Thom, Botany Department, University of Wyoming, Laramie, WY U.S.A. RHP, Ronald H. Petersen, Department of Botany, University of Tennessee, Knoxville, TN U.S.A. RV and DUKE, Rytas Vilgalys, Department of Botany, Duke University, Durham, NC U.S.A. STCL, Shu-Ting Chang, Chinese University of Hong Kong, Hong Kong, China. TMI, Tottori Mycological Institute, Tottori, Japan. VB, Viktor. T. Bilay, M. G. Kholodny Institute of Botany, Kiev, Ukraine. DSH, personal culture collection of DSH.

additional primers, ITS1, ITS3, and 5.8S (White *et al.*, 1990; Hibbett *et al.*, 1995), were used in dye-terminator cycle sequencing (Applied Biosystems, Foster City, California). Sequencing reactions were run on Applied Biosystems 370 or 377 automated DNA sequencers. Sequences were edited and assembled using either SeqEd (Applied Biosystems) or Sequencher 3.0 (GeneCodes, Ann Arbor, Michigan). Sequences have been deposited in GenBank (accessions AF031175–AF031193).

Sequences were manually aligned in the data editor of

PAUP* 4.0d55 (kindly provided by David Swofford, Smithsonian Institution, Washington, D.C.). Sequences were coded for parsimony analysis either with gaps scored as missing data (gap = missing coding), or with insertion-deletions (indels) coded as characters (indel coding; see Hibbett *et al.*, 1995). The data matrix is available from DSH or TreeBASE (<http://phylogeny.harvard.edu/treebase>).

Maximum parsimony and bootstrap analyses were performed with PAUP* 4.0d55. Each maximum parsimony analysis was performed in two parts. First, one hundred

heuristic searches were performed with random taxon addition and TBR branch swapping, with MAXTREES unrestricted, keeping up to two trees per replicate. Secondly, all the shortest trees from the first part of the analysis were used as starting trees for complete TBR branch swapping, with MAXTREES set at 15000. Bootstrap analyses used one hundred heuristic searches, with MAXTREES set at one hundred, simple taxon addition sequences, and TBR branch swapping.

The main parsimony analyses (and all bootstrap analyses) used all six isolates of *L. boryana* for rooting purposes. In our previous study (Hibbett *et al.*, 1995), the placement of the ingroup root was problematical, possibly due to a high degree of divergence between the ingroup and outgroup sequences. In the present study, the ITS sequence of the *L. boryana* isolate from Louisiana (U.S.A.) was found to be very different from the ITS sequences of the five Central American *L. boryana* isolates (see Results). To examine the sensitivity of the root to the choice of outgroup sequences, we performed parsimony analyses, under both indel coding and gap = missing coding, which were rooted using either the U.S.A. *L. boryana* isolate, or the five *L. boryana* isolates from Central America.

Pairwise percent sequence similarities were calculated using PAUP* under gap = missing coding (Table 2). These were calculated using only ITS1 and ITS2 (excluding the 5.8S rDNA) from nine representative isolates, including three *L. boryana* isolates (from North and Central America) and six shiitake isolates (representing all rDNA lineages).

Topologically constrained parsimony analyses were performed to evaluate suboptimal tree topologies. MacClade 3.0 (Maddison & Maddison, 1992) was used to construct constraint trees that forced the monophyly of either (i) all isolates from continental Asia and Japan, or (ii) all isolates from PNG. No other topological structure was specified by the constraint trees. Constrained analyses used all six *L. boryana* isolates, with indel coding, and the same PAUP* settings as the unconstrained analyses. Constrained trees were compared to unconstrained trees using Templeton's non-parametric test of parsimony (Templeton, 1983; *cf.* Hibbett *et al.*, 1995; Larson, 1994). Templeton's test was chosen because it allows inclusion of indel characters and does not require fully dichotomized trees.

RESULTS

Sequences of ITS1 ranged from approximately 246 to 258 base pairs (bp) in *L. boryana*, and from 235 to 237 bp in shiitake. ITS2 ranged from approximately 297 to 315 bp in *L. boryana*, and from 273 to 277 bp in shiitake. ITS1 and ITS2 were aligned along with the intervening 5.8S rDNA (158 bp) and flanking partial sequences of 18S and 25S rDNA (55 bp total). Most regions of the sequence could be aligned across all the isolates, except for one region of 59 to 66 bp in ITS1 and another region of 47 to 70 bp in ITS2 (Fig. 1). Within these regions, it was possible to align the ingroup shiitake sequences, or the Mexican and Costa Rican isolates of *L. boryana*, but these could not be aligned to each other, and neither could be aligned to the isolate of *L. boryana* from North America. These divergent regions were offset in the

matrix and padded out with question marks, which added approximately 200 bp to the alignment. The aligned length of all sequences including the offset regions was 1010 bp. Under gap = missing coding, there were 113 parsimony-informative sites. Under indel coding, there were 149 informative characters, including 40 informative indel characters. All informative variation was in the ITS1 and ITS2.

Percent sequence similarity in ITS1 and ITS2 between *L. boryana* and shiitake ranged from approximately 80% to 88% (Table 2). Within *L. boryana*, the North American isolate was approximately 79% similar to the Costa Rican and Mexican isolates, which were approximately 98% similar in sequence. Within shiitake, percent sequence similarity between rDNA lineages ranged from approximately 93% (group I/group II) to 98% (group II/group III).

Parsimony analyses under gap = missing coding produced over 15000 equally parsimonious trees of 175 steps (consistency index [CI] = 0.817, retention index [RI] = 0.951). Despite the large number of trees, the strict consensus tree is highly resolved (Fig. 2). All but two of the new isolates were nested in one of the four rDNA lineages (groups I–IV) that we identified previously (Hibbett *et al.*, 1995). Group I, which was supported by 85% of the bootstrap replicates, includes six of the seven Chinese isolates, both North Korean and Thai isolates, all of the Japanese isolates, and the one isolate from Borneo. The isolate from Borneo (BOR, TMI 689) is the sister group to the rest of group I, which we call group Ia. Monophyly of group Ia is supported by 88% of the bootstrap replicates. Nested within group Ia is a strongly supported lineage (group Ib, bootstrap = 100%) that includes both Thai isolates and five of the Chinese isolates. Group II, which is supported by 96% of the bootstrap replicates, contains seven of the nine isolates from PNG, all three Australian isolates, and the one isolate from Tasmania. Within group II, two isolates from PNG are strongly supported as monophyletic (group IIa, bootstrap = 100%). Groups III and IV are unchanged from our previous analysis (Hibbett *et al.*, 1995). Group III contains all five isolates from New Zealand (bootstrap = 85%), and group IV contains two isolates from PNG (bootstrap = 99%). Group V is a strongly supported (bootstrap = 98%) lineage that is resolved for the first time in this study. It includes the one isolate from Nepal and one of the seven isolates from China.

Under gap = missing coding, groups II, III and V formed a moderately strongly supported monophyletic group (bootstrap = 71%), within which groups II and V are sister lineages (bootstrap = 67%). In the strict consensus tree, the basal node of the ingroup topology is unresolved, with groups I and IV and the group II, III and V lineage forming a trichotomy (Fig. 2). Approximately two-thirds of the equally parsimonious trees (10020 trees) had the ingroup root placed along the branch leading to group I. Following the terminology of our previous study (Hibbett *et al.*, 1995, Fig. 3), in which we evaluated multiple rooting options, this is root E. The remaining trees (4980 trees) had the ingroup root placed along the branch leading to group IV, which we previously called root A. Analyses that were rooted using only the North American *L. boryana* isolate produced over 15000 trees of 105 steps, all with root E. Analyses that were rooted using the

<--18S

L. boryana – CRA
L. boryana – USA
 group I – JPN3
 group II – PNG5
 group III – NZL1
 group IV – PNG4
 group V – NEP

CCGTAGGTGAACCTGCGGAAGGATCAATTTGAATTTTTGGTGG-TAGACTGTGTGGCTTTT-----TACAAGGTAATGTGCACGCTCTTCCTGCTA
 CCCTAGGTGAACCTGCGGAAGGATCAATTTGAATTTTTGGTGG-TAGACTGTGTGGCTTTTCTAAAAAAGGTTTGCA-----TGTCAGCTGTTCCTCACTA
 CCCTAGGTGAACCTGCGGAAGGATCAATTTGAATTTTTGGTGG-TAGACTGTGTGGCTTTTCTAAAAAAGGTTTGCA-----GGGTA-TGTGCACATCCCTCCCG
 CCCTAGGTGAACCTGCGGAAGGATCAATTTGAATTTTTGGTGG-TAGACTGTGTGGCTTTTCTAAAAAAGGTTTGCA-----GGGTA-TGTGCACATCCCTCCCTG
 CCCTAGGTGAACCTGCGGAAGGATCAATTTGAATTTTTGGTGG-TAGACTGTGTGGCTTTTCTAAAAAAGGTTTGCA-----GGGTA-TGTGCACATCCCTCCCTG
 CCCTAGGTGAACCTGCGGAAGGATCAATTTGAATTTTTGGTGG-TAGACTGTGTGGCTTTTCTAAAAAAGGTTTGCA-----GGGTA-TGTGCACATCCCTCCCTG

L. boryana – CRA
L. boryana – USA
 group I – JPN3
 group II – PNG5
 group III – NZL1
 group IV – PNG4
 group V – NEP

ATTTC-ATTTCACCACTGTGCATTTCTGTAGGAGAACTTTTTTCAT-----
 ATTTC-ATTTCACCACTGTGCATTTCTGTAGGAGAACTTTTTTCAT-----
 ATTTCATTTCACCACTGTGCATTTCTGTAGGAG-----TTCTTCATCGGGTTTTGA--AGGTG-CTCATT--TGAGTA-CT-G-AAAAGACTAGTGT
 ATT-CTATTTCACCACTGTGCATTTCTGTAGGAG-----TTCTTCATCGGGTTTTGT--AGGTG-CTCATT--ACGAGTTAAGCTG-TGAAGACTGTGTG
 ATT-CTATTTCACCACTGTGCATTTCTGTAGGAG-----TTCTTCATCGGGTATT--AACAGGTG-CTCATT--CGAGTTAAGCTGTGGAAAGACTAGTGT
 ATT-CTATTTCACCACTGTGCATTTCTGTAGGAG-----TTCTTCATCGGGT--TTTGA-AGGTG-CTCATTATATAGTA-CTGTGAACTGCTGTGCTG
 ATT-CTATTTCACCACTGTGCATTTCTGTAGGAG-----TTCTTCATCGGGTTT--GAACAGGTG-CTCATT--CGAGTTAAGCTGTGGAAAGACTAGTGT

L. boryana – CRA
L. boryana – USA
 group I – JPN3
 group II – PNG5
 group III – NZL1
 group IV – PNG4
 group V – NEP

-----GGGTTTTGACATTTTCATATATATATAGTGTTTTAACTATGAGAAAGG-----C
 -----GGGTTTTGACATTTTCATATATATATAGTGTTTTAACTATGAGAAAGG-----C
 ACA--GG-----TCATTTGTGATAACATATATGTTTTCATATTTGTGAGGCAAAATGGAGGTTCC
 AAAA--GA-----
 AAAA--GA-----
 AAAAGGG-----
 AAAA--GA-----

L. boryana – CRA
L. boryana – USA
 group I – JPN3
 group II – PNG5
 group III – NZL1
 group IV – PNG4
 group V – NEP

TTCTATGT-CTCACAATCATTGAA-GTATGTTATAGAATGACTTTTTTTTGGGGCTTTATGACCATTAACTTAATACAACCTTCAGCAACGGATCTCTTGGCTCTCC
 TTCTATGTCTTCACAATGATTCAAAGTATGTTAAAGAAATGAACACAATATGGGACTTCATGACCATTGAACTTAATACAACCTTCAGCAACGGATCTCTTGGCTCTCC
 TTCTATGTCTTCACAATGATTCAAAGTATGTTAAAGAAATGAACACAATATGGGACTTCATGACCATTGAACTTAATACAACCTTCAGCAACGGATCTCTTGGCTCTCC
 TTCTATGTCTTCACAATGATTCAAAGTATGTTAAAGAAATGAACACAATATGGGACTTCATGACCATTGAACTTAATACAACCTTCAGCAACGGATCTCTTGGCTCTCC
 TTCTATGTCTTCACAATGATTCAAAGTATGTTAAAGAAATGAACACAATATGGGACTTCATGACCATTGAACTTAATACAACCTTCAGCAACGGATCTCTTGGCTCTCC
 TTCTATGTCTTCACAATGATTCAAAGTATGTTAAAGAAATGAACACAATATGGGACTTCATGACCATTGAACTTAATACAACCTTCAGCAACGGATCTCTTGGCTCTCC

5.8S-->

L. boryana – CRA
L. boryana – USA
 group I – JPN3
 group II – PNG5
 group III – NZL1
 group IV – PNG4
 group V – NEP

CATCGATGAAGAACCGCAAGTGGGATAAGTAAATGTAATGTCAGAAATTCAGTGAATCATCGAATCTTTGAACGCACCTTGGCCCTCTGGTATTCGGAGGGCATGCTG
 CATCGATGAAGAACCGCAAGTGGGATAAGTAAATGTAATGTCAGAAATTCAGTGAATCATCGAATCTTTGAACGCACCTTGGCCCTCTGGTATTCGGAGGGCATGCTG
 CATCGATGAAGAACCGCAAGTGGGATAAGTAAATGTAATGTCAGAAATTCAGTGAATCATCGAATCTTTGAACGCACCTTGGCCCTCTGGTATTCGGAGGGCATGCTG
 CATCGATGAAGAACCGCAAGTGGGATAAGTAAATGTAATGTCAGAAATTCAGTGAATCATCGAATCTTTGAACGCACCTTGGCCCTCTGGTATTCGGAGGGCATGCTG
 CATCGATGAAGAACCGCAAGTGGGATAAGTAAATGTAATGTCAGAAATTCAGTGAATCATCGAATCTTTGAACGCACCTTGGCCCTCTGGTATTCGGAGGGCATGCTG
 CATCGATGAAGAACCGCAAGTGGGATAAGTAAATGTAATGTCAGAAATTCAGTGAATCATCGAATCTTTGAACGCACCTTGGCCCTCTGGTATTCGGAGGGCATGCTG

<--5.8S

L. boryana – CRA
L. boryana – USA
 group I – JPN3
 group II – PNG5
 group III – NZL1
 group IV – PNG4
 group V – NEP

TTTGAGTGTCTTAAATTTCTCAACTCAACCAAGTTTTACGACTTGTATGAAAGC-----TTGGATGT-GGA-GGCTTGTCT-GGCATTGTTTTCAGCTCTCTCT
 TTTGAGTGTCTTAAATTTCTCAACTCAACCAAGTTTTACGACTTGTATGAAAGC-----TTGGATGT-GGA-GGCTTGTCT-GGCATTGTTTTCAGCTCTCTCT
 TTTGAGTGTCTTAAATTTCTCAACTCAACCAAGTTTTACGACTTGTATGAAAGC-----TTGGATGT-GGA-GGCTTGTCT-GGCATTGTTTTCAGCTCTCTCT
 TTTGAGTGTCTTAAATTTCTCAACTCAACCAAGTTTTACGACTTGTATGAAAGC-----TTGGATGT-GGA-GGCTTGTCT-GGCATTGTTTTCAGCTCTCTCT
 TTTGAGTGTCTTAAATTTCTCAACTCAACCAAGTTTTACGACTTGTATGAAAGC-----TTGGATGT-GGA-GGCTTGTCT-GGCATTGTTTTCAGCTCTCTCT
 TTTGAGTGTCTTAAATTTCTCAACTCAACCAAGTTTTACGACTTGTATGAAAGC-----TTGGATGT-GGA-GGCTTGTCT-GGCATTGTTTTCAGCTCTCTCT

L. boryana – CRA
L. boryana – USA
 group I – JPN3
 group II – PNG5
 group III – NZL1
 group IV – PNG4
 group V – NEP

AAACATATTAGTGGAGAAA--ACCCGTTT-TGCTGATCC--AAACATA--AAGGTGTGATAATTAATCTACATTTTGGTT-----
 AAATATATCAGTGGATTTAAACCCCTGCTTTGATGCC--AACCGTTTAAAGGTGATAATTAATCTACGCTTTTAAAC-----
 AAATTTATTAGTGGAA-----ACCCGTTTGGTGTAGTTCT--AACTT-----GGTGTGATAATTAATCTACATTTT--GGT--GGAA--CCTTACAATAAT--AAAGCTTATT
 AAATTTATTAGTGGAA-----CCCTGTTTGGTGTAGTTCT--AACTT-----GGTGTGATAATTAATCTACATTTT--GGTGTGATAATTAATCTACATTTT--GGTGTGATAATTAATCTACATTTT--AAAGCTTATT
 AAATTTATTAGTGGAA-----CCCTGTTTGGTGTAGTTCT--AACTT-----GGTGTGATAATTAATCTACATTTT--GGTGTGATAATTAATCTACATTTT--GGTGTGATAATTAATCTACATTTT--AAAGCTTATT
 AAATTTATTAGTGGAA-----CCCTGTTTGGTGTAGTTCT--AACTT-----GGTGTGATAATTAATCTACATTTT--GGTGTGATAATTAATCTACATTTT--GGTGTGATAATTAATCTACATTTT--AAAGCTTATT

L. boryana – CRA
L. boryana – USA
 group I – JPN3
 group II – PNG5
 group III – NZL1
 group IV – PNG4
 group V – NEP

-----AGTTCGAAGTTTTCCTGCTTTGATATCTTAGGCTGTGCATTAAGTTGCTCGGTTTGTGGGTTGCTGCAATTTGCTCAATCTGTTG-ATT
 -----AGTTG--GTTTCAGAG--TTACTTTTGA-----TTGGGTTGTGTTGC-----TTGCTCAATCTGTTTCTATT
 GGTTTGGGTTGTGTTGA-----TTAGTTTGTCTCAATCTGTTTCT-ATT
 GGTTTGGGTTGTGTTGA-----TTAGTTTGTCTCAATCTGTTTCT-ATT
 GGTTTGGGTTGTGTTGA-----TTAGTTTGTCTCAATCTGTTTCT-ATT
 GGTTTGGGTTGTGTTGA-----TTAGTTTGTCTCAATCTGTTTCT-ATT
 GGTTTGGGTTGTGTTGA-----TTAGTTTGTCTCAATCTGTTTCT-ATT

L. boryana – CRA
L. boryana – USA
 group I – JPN3
 group II – PNG5
 group III – NZL1
 group IV – PNG4
 group V – NEP

CACGTGAG--AGTAACAA--GGG--AAG--TCTGCTTTCTAAGTCTCT--CTAATAGGACA--A--CT-TATATTTTTGGTGTGACCTCAATCA?GTAGGATTACC
 CATTAGAGTTTGTATCAAAAGGG--AGTCACTGCTTTCTAAGCTGCTCTGTTTCT--GGACA--A--CTCTATATTTTTGCTGTGACCTCAATCAAGT?GATTACC
 CATTAGAG--AAAAA--GGG--A--TC-CTTTCAACTGCTTTGATGACTATATATA--CT-TAT--TTGC?TGACCTCAATCAAGT?GATTAGGATTACC
 CATTAGAG--AAAAA--GGG--?AG-CTCTGCTCTCTCTGTTCTTTTGGTCAATATATAA--CT-TAT--TTGCTGTGACCTCAATCAAGT?GATTAGGATTACC
 CATTAGAG--AAAAA--GGG--AAGG-TCTGCTTTCTAAGTCTCTTTTGAAGTATATATAA--CT-TAT--TTGCTGTGACCTCAATCAAGT?GATTAGGATTACC
 CATTAGAG--AAAAA--GGG--AAGG-TCTGCTTTCTAAGTCTCTTTTGAAGTATATATAA--CT-TAT--TTGCTGTGACCTCAATCAAGT?GATTAGGATTACC
 CATTAGAG--AAAAA--GGG--AAGG-TCTGCTTTCTAAGTCTCTTTTGAAGTATATATAA--CT-TAT--TTGCTGTGACCTCAATCAAGT?GATTAGGATTACC

25S-->

Fig. 1. Aligned sequences of ITS1 and 2 and 5.8S rDNA from seven isolates representing *L. boryana* from Central America and North America, and groups I–V of Asian–Australasian *Lentinula*. Coding regions of 18S, 5.8S, and 25S rDNA are labelled and underlined in the first sequence. Divergent regions that could not be aligned across all isolates are indicated with asterisks.

Central American *L. boryana* isolates produced over 15 000 trees of 150 steps, all with root A.

Parsimony analyses under indel coding and using all *L. boryana* isolates produced 25 equally parsimonious trees of 247 steps (CI = 0.810, RI = 0.947). There is a high degree of topological congruence with the trees derived from gap = missing coding, and similar levels of bootstrap support for groups I–V (Fig. 3). The major topological differences under indel coding are that group V and group III form a monophyletic group (v. group V and group II) and root E is supported in all equally parsimonious trees. Analyses that

were rooted using only the new North American *L. boryana* isolate produced five trees (151 steps), all with root E, but analyses that were rooted using the Central American *L. boryana* isolates produced 65 trees (147 steps), all with root A.

Topologically constrained analyses under indel coding that forced monophyly of the PNG isolates produced 10 trees that were five steps (2%) longer than the unconstrained trees, but that were not rejected by the Templeton test ($n = 13$, $T_s = 26$). Topologically constrained analyses under indel coding that forced monophyly of the Japanese and continental Asian isolates produced 10 trees that were 17 steps (7%) longer than

Table 2. Pairwise percent sequence similarity among ITS1 and ITS2 of representative isolates (see Table 1 for isolate codes)

	CRA	MEX2	USA	JPN4	JPN3	PNG5	PNG4	TAS	NZL1
<i>L. boryana</i>									
CRA	—	0.98	0.79	0.88	0.88	0.87	0.87	0.88	0.88
MEX2		—	0.79	0.88	0.87	0.86	0.86	0.87	0.87
USA			—	0.82	0.82	0.80	0.80	0.81	0.82
shiitake									
JPN4 – group I				—	0.99	0.94	0.95	0.96	0.97
JPN3 – group I					—	0.93	0.95	0.96	0.96
PNG5 – group II						—	0.93	0.98	0.96
PNG4 – group IV							—	0.95	0.96
TAS – group II								—	0.98
NZL1 – group III									—

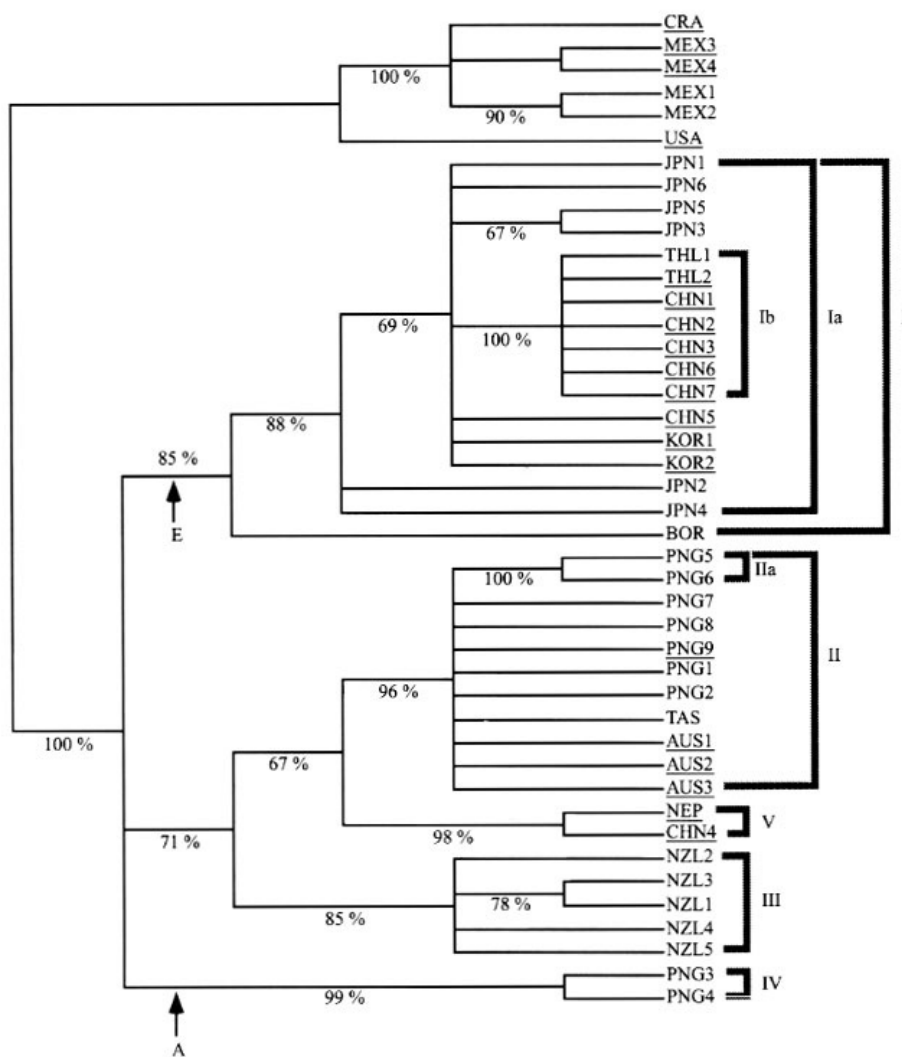

Fig. 2. Strict consensus of 15 000 equally parsimonious trees (175 steps, CI = 0.817, RI = 0.951) generated under gap = missing coding. Terminal taxa are individual isolates (see Table 1). Numbers below branches are frequency of occurrence in 100 bootstrap replicates. Underlined isolates are new to this study. Arrows with letters indicate rooting options A and E (see text). Bracketed groups I–V are discussed in text.

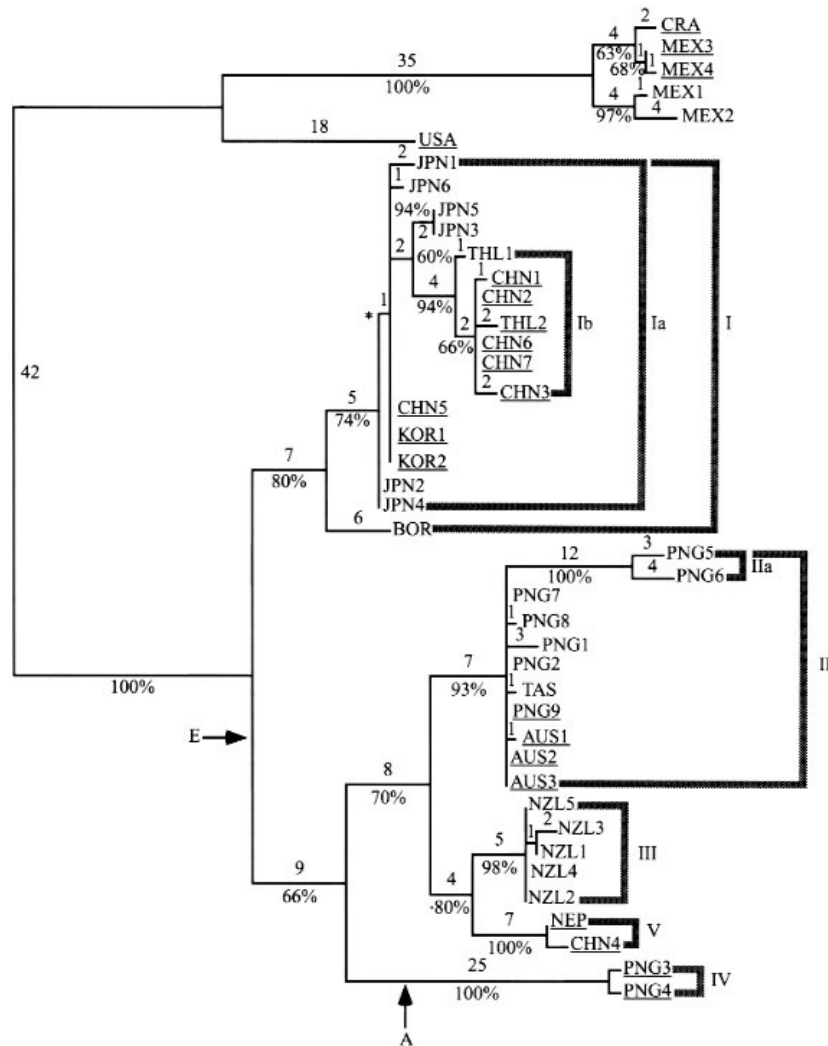

Fig. 3. Phylogram depicting one of 25 equally parsimonious trees (247 steps, CI = 0.810, RI = 0.947) generated under indel coding. Branch lengths are proportional to the number of steps along the branch (given above each branch). Branch that collapses in strict consensus tree is indicated with an asterisk. Other symbols are as in Fig. 2.

the unconstrained trees, and which were rejected by the Templeton test ($n = 22$, $T_s = 38$, $P < 0.01$).

DISCUSSION

Phylogenetic analyses of ITS sequences identified five main lineages of shiitake, which we call groups I–V. Groups I–V are supported as monophyletic in all analyses, with bootstrap values from 80 to 100% (Figs 2–3). Higher-level relationships among these groups are not well resolved, however. Due to rooting ambiguities, only the group II, III and V clade is monophyletic in all analyses, but it is not strongly supported (bootstrap = 70%). Furthermore, trees produced in constrained analyses that forced the monophyly of isolates from PNG (including group IV and some members of group II) could not be rejected by the Templeton test. As in our previous analyses (Hibbett *et al.*, 1995), the position of the ingroup root is particularly problematical. All trees supported

either root A or root E, depending on which *L. boryana* sequences were used to root the trees, but these alternatives are equally parsimonious (Figs 2–3). The longest branch in our trees is the branch connecting the outgroup to the ingroup (Fig. 3), which raises the possibility that convergent evolution along the long branches ('long branch attraction'; Felsenstein, 1978) is a source of error in the placement of the root.

The ITS of the North American *L. boryana* isolate is approximately 79% similar in sequence to the ITS of the Central American *L. boryana* isolates (which are approximately 98% similar to each other, Table 2). In contrast, ITS of the most divergent shiitake isolates are approximately 93% similar in sequence (Table 2). One possible explanation for this is that there is heterogeneity in rates of rDNA sequence evolution among lineages in *Lentinula*. Alternatively, if rates are more or less clocklike, then there are two possible explanations: Either *L. boryana* and shiitake are both monophyletic and the most recent common ancestor of the *L.*

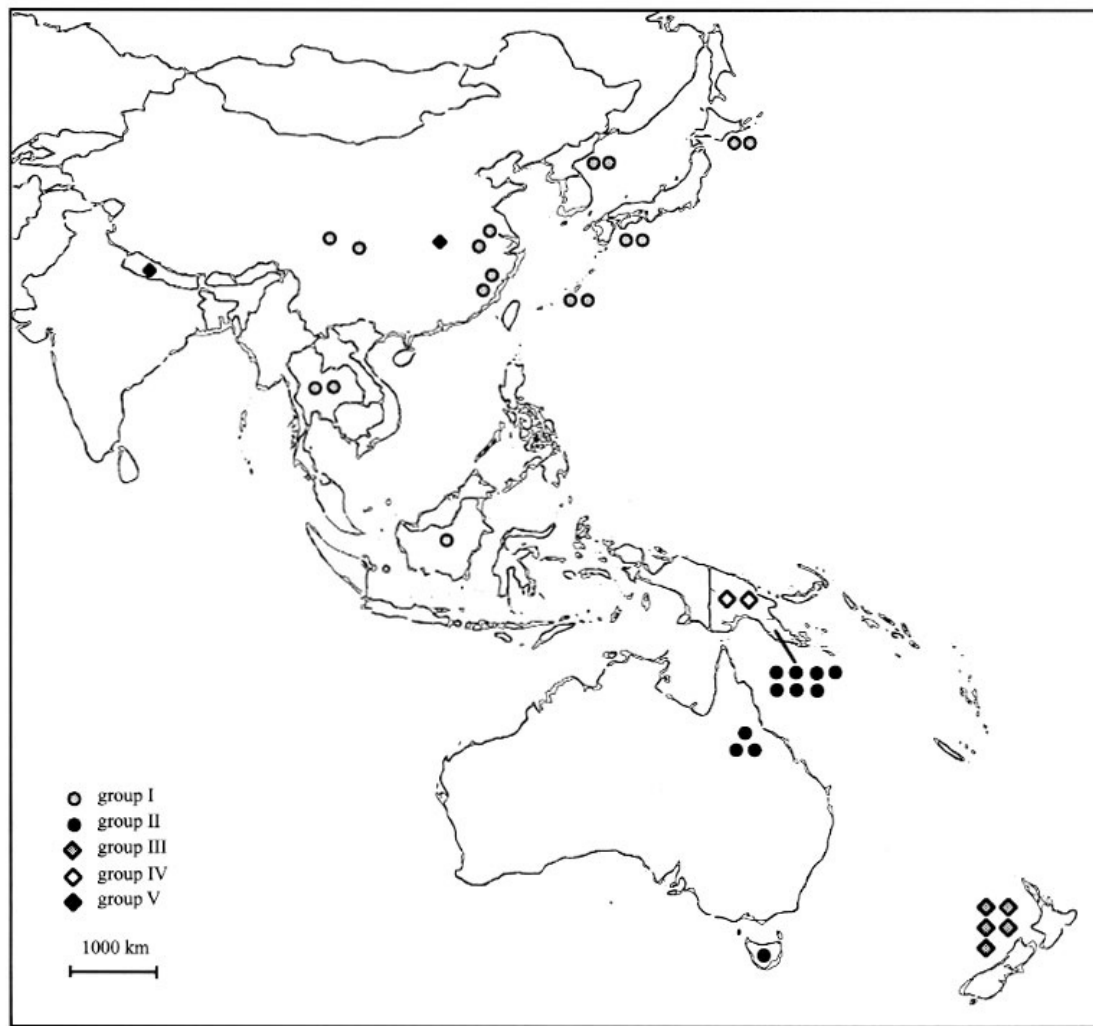

Fig. 4. Approximate distribution of Old World *Lentinula* isolates examined in this study in Asia–Australasia, showing rDNA lineages I–V.

boryana isolates is older than that of the shiitake isolates, or *L. boryana* is paraphyletic. Given our concern that long branch attraction is source of error, and our observation that the position of the ingroup root is sensitive to the choice of outgroup sequences, it would be valuable to know whether *L. boryana* is, in fact, paraphyletic.

Recently, Nicholson, Bunyard & Royse (1997) performed a phenetic analysis of rDNA restriction fragment length polymorphisms in shiitake and *L. boryana* (including some of the same *Lentinula* isolates used in the present study), which was rooted with *Collybia*, *Clitocybula*, and *Pleurotus*. Nicholson *et al.*'s results suggested that *L. boryana* is monophyletic, but their study included only Central American *L. boryana* isolates (Dan Royse, pers. comm.). To critically address the monophyly of *L. boryana*, it will be necessary to perform phylogenetic analyses that include geographically diverse isolates of both shiitake and *L. boryana* in the ingroup. Morphology and molecular phylogenies suggest that *Collybia* is an appropriate outgroup for such an analysis (Pegler, 1983; Hibbett, 1992;

Hibbett & Vilgalys, 1993). Sequence divergence in the ITS within *Lentinula* is already so great that the ITS cannot be aligned in all regions across all isolates. For a higher-level study of *Lentinula*, genes that evolve more slowly than the ITS would be needed, such as the nuclear large-subunit rDNA (nuc-lsu-rDNA).

Phylogenetic relationships of most of the new shiitake isolates in this study are consistent with expectations based on geographic distributions (Fig. 4). The new Australian isolates are nested in group II, which previously included isolates from PNG and Tasmania. These results suggest that group II has a continuous range from PNG through Tasmania (Fig. 4). The range of group II overlaps part of the range of the morphological species *L. lateritia*, which also occurs in southeast Asia (Pegler, 1983). The new Thai, Korean, and six of seven Chinese isolates are nested in group Ia, which previously included Japanese and Thai isolates. Group I now appears to have a range that encompasses northeast and continental Asia, including southeast Asia and at least part of

the South Pacific (Fig. 4). The range of group I overlaps all of the range of *L. edodes* and part of the range of *L. lateritia* (Pegler, 1983). Cultivated shiitake is thought to be derived from northeast Asian strains, based on morphology (Pegler, 1983), and isozymes (Royse & May, 1987). We expect that most, if not all, commonly cultivated shiitake strains carry group I rDNAs.

A major discovery of this study is that there is a fifth rDNA lineage of shiitake in continental Asia, which we call group V. Group V contains one isolate from eastern China and one isolate from Nepal, which is close to the putative range limit of shiitake (Fig. 4). The Nepalese group V isolate is the only collection in our study from the Himalayan regions. It would be especially valuable to sample more isolates from the Himalayan regions, such as Nepal, Bhutan, Tibet and northern India. It is not clear which of the other rDNA lineages is most closely related to group V. Analyses under gap = missing coding suggested that group V is the sister group of group II (PNG–Australia–Tasmania), but analyses under indel coding suggested that group V is the sister group of group III (New Zealand). Although there is ambiguity regarding the closest relative of group V, constraint trees that forced monophyly of groups Ia and V (continental and northeast Asia) were rejected by the Templeton test. Even though groups I and V overlap in eastern China, it appears that they are not sister lineages.

Our geographic sampling of shiitake is still very fragmentary. Nevertheless, our results suggest that there are certain regions that harbour several rDNA lineages (Fig. 4). These areas deserve intensive sampling and should be targeted for conservation efforts (Hibbett & Donoghue, 1996). One such area, which we discussed previously (Hibbett *et al.*, 1995; Hibbett & Donoghue, 1996), is PNG, where groups II and IV co-occur. Within PNG, both isolates of group IV are from Mt Wilhelm, in the central Highlands region, whereas the seven isolates of group II are from various locations in Central and Morobe provinces, which are approximately 80–240 km east of the Highlands region (Table 1). Further sampling is needed to understand the diversity and distribution of rDNA lineages in PNG.

Another area of high diversity, which we had not sampled previously, is eastern China, where groups I and V co-occur. Shiitake is major crop in this area. A recent study by Chiu *et al.* (1996) using random PCR-generated DNA polymorphisms found that 19 Chinese shiitake cultivars were genetically very homogeneous as compared to three wild isolates from Fujian province in eastern China. Taken together, our results and those of Chiu *et al.* (1996) suggest that wild shiitake populations in China harbour considerable genetic diversity. As we discussed previously (Hibbett & Donoghue, 1996), in areas where there are both cultivated and wild shiitake populations, the indigenous populations face potential threats from competition and interbreeding with escaped cultivars (as well as the usual threats from habitat loss). Indigenous shiitake populations in China are surely among the most endangered, owing to their proximity to large cultivated populations.

Lentinula has a complex biogeography, with populations on four continents, representing both Gondwana and Laurasia. Within the Old World shiitake clade, some rDNA lineages appear to be narrowly distributed (groups III, IV), whereas

others are broadly distributed (groups I, II) and overlap the ranges of other groups. The present distribution of *Lentinula* must result from some combination of vicariance, dispersal, and extinction. In addition, recent human activities related to cultivation may have altered the natural distribution of certain *Lentinula* genotypes, especially in east Asia, where shiitake has been cultivated for approximately 1000 yr (Chang & Miles, 1987).

Methods for inferring historical biogeographic patterns are controversial. Whereas the ancestral area and changes in the distribution of a lineage can be inferred using only the phylogeny of that lineage (e.g. Bremer, 1992; Ronquist, 1997), general biogeographic patterns can only be understood in the context of multiple phylogenies of unrelated taxa (Nelson & Platnick, 1981). In either approach, accurate phylogenetic hypotheses are needed, along with thorough geographic sampling. In *Lentinula*, significant phylogenetic questions remain unanswered and many regions are still unsampled. Furthermore, our understanding of the phylogeny of *Lentinula* is based on just a single locus. Laboratory mating studies have demonstrated that populations of *Lentinula* from throughout the Old World have the potential to interbreed, and a phenetic analysis of mitochondrial DNA RFLPs (Fukuda *et al.*, 1994) supported a different topology from that suggested by rDNA. Consequently, there is reason to be concerned that the rDNA phylogeny might not correspond to the phylogeny of other genes, or of populations, in *Lentinula*.

In addition to those whom we acknowledged previously (Hibbett *et al.*, 1995), we thank Pimarn Arampongphan, Viktor T. Bilay, Shu-Ting Chang, Huang N. Lai, Greg Thorn, and Rytas Vilgalys for providing isolates. We also thank Dan Royse for information regarding isolates in the Penn State University Mushroom Culture Collection. This research was supported by a grant from the Martin-Baker Endowment Fund of the Mycological Society of America and NSF grants DEB-9303268 and DEB-9629427.

REFERENCES

- Bremer, K. (1992). Ancestral areas: a cladistic reinterpretation of the center of origin concept. *Systematic Biology* **41**, 436–445.
- Chang, S.-T. & Miles, P. G. (1987). Historical record of the early cultivation of *Lentinus* in China. *Mushroom Journal of the Tropics* **7**, 31–37.
- Chiu, S.-W., Ma, A.-M., Lin, F.-C. & Moore, D. (1996). Genetic homogeneity of cultivated strains of shiitake (*Lentinula edodes*) used in China as revealed by the polymerase chain reaction. *Mycological Research* **100**, 1393–1399.
- Felsenstein, J. (1978). Cases in which parsimony or compatibility methods will be positively misleading. *Systematic Zoology* **27**, 401–440.
- Fukuda, M., Fukumasa-Nakai, Y., Hibbett, D. S., Matsumoto, T. & Hayashi, Y. (1994). Mitochondrial DNA restriction fragment length polymorphisms in natural populations of *Lentinula edodes*. *Mycological Research* **98**, 169–175.
- Hibbett, D. S. (1992). Towards a phylogenetic classification for shiitake: taxonomic history and molecular perspectives. *Reports of the Tottori Mycological Institute* **30**, 30–42.
- Hibbett, D. S. & Donoghue, M. J. (1996). Implications of phylogenetic studies for conservation of genetic diversity in shiitake mushrooms. *Conservation Biology* **10**, 1321–1327.
- Hibbett, D. S., Fukumasa-Nakai, Y., Tsuneda, S. & Donoghue, M. J. (1995). Phylogenetic diversity in shiitake inferred from nuclear ribosomal DNA sequences. *Mycologia* **87**, 618–638.
- Hibbett, D. S. & Vilgalys, R. (1993). Phylogenetic relationships of *Lentinus*

- (Basidiomycotina) inferred from molecular and morphological characters. *Systematic Botany* **18**, 409–433.
- Larson, A. (1994). The comparison of morphological and molecular data in phylogenetic systematics. In *Molecular Ecology and Evolution: Approaches and Applications* (ed. B. Schierwiler, B. Streit, G. P. Wagner & R. DeSalle), pp. 371–390. Birkhäuser Verlag: Basel, Switzerland.
- Maddison, W. P. & Maddison, D. R. (1992). *Macclade version 3*. Sinauer Associates Inc.: Sunderland, U.S.A.
- Nelson, G. & Platnick, N. (1981). *Systematics and Biogeography*. Columbia University Press: New York, U.S.A.
- Nicholson, M. S., Bunyard, B. A. & Royse, D. J. (1997). Phylogeny of the genus *Lentinula* based on ribosomal DNA restriction fragment length polymorphism analysis. *Mycologia* **89**, 400–407.
- Pegler, D. N. (1983). The genus *Lentinula* (Tricholomataceae tribe Collybieae). *Sydowia* **36**, 227–239.
- Ronquist, F. (1997). Dispersal-vicariance analysis: a new approach to the quantification of historical biogeography. *Systematic Biology* **46**, 195–203.
- Royse, D. J. & May, B. (1987). Identification of shiitake genotypes by multilocus enzyme electrophoresis: catalog of lines. *Biochemical Genetics* **25**, 705–716.
- Shimomura, N., Hasebe, K., Nakai-Fukumasa, Y. & Komatsu, K. (1992). Intercompatibility between geographically distant strains of shiitake. *Reports of the Tottori Mycological Institute* **30**, 26–29.
- Templeton, A. (1983). Phylogenetic inference from restriction endonuclease cleavage site maps with particular reference to the evolution of humans and the apes. *Evolution* **37**, 221–224.
- White, T. J., Bruns, T. D., Lee, S. & Taylor, J. W. (1990). Amplification and direct sequencing of fungal ribosomal genes for phylogenetics. In *PCR Protocols* (ed. M. A. Innis, D. H. Gelfand, J. J. Sninsky & T. White), pp. 315–322. Academic Press: San Diego, U.S.A.

(Received 5 November 1997)